



The Chemical Company

MASTERFLOW[®] 648 CP PLUS

High Temperature, High Strength, Precision Grout for Heavy Dynamic and Static Loads

Description of Product

MASTERFLOW[®] 648 CP PLUS is a three component modified epoxy resin based grout. The final viscosity and flow characteristics can be adjusted to suit the particular project and application by varying the quantity of filler. MASTERFLOW[®] 648 CP PLUS combines high temperature performance and crack resistance with outstanding flow characteristics.

Fields of Application

Grouting and bedding of machinery, structures and crane rails in the harshest industrial environments. For example:

- Gas Transmission Industry:
very large reciprocating compressors
- Steel Industry:
crushers, ball mills, rod mills, slab tables
- Petrochemical
- Mining
- Paper and Pulp
- Power generation

Features and Benefits

- High ultimate compressive, flexural and tensile strengths. Therefore able to withstand heavy static and dynamic loads.
- Rapid curing reduces downtime and allows prompt scheduling of new installation.
- Excellent adhesion to steel and concrete ensuring full transmission of loads.
- Resists many industrial chemicals allowing use in harsh environments.
- Very low shrinkage ensures full contact at load transfer.
- 40 year track record in heavy industrial conditions provides confidence to new specifiers of clients.
- Maintains very high performance even at higher working temperatures with reduced creep and ensures precision alignment is maintained.
- Specifically designed to allow a variable filler ratio to optimise flowability, bearing area and economics.
- Can be applied in thicknesses ranging from 12 - 150 mm.



The Chemical Company

Typical Properties/ Technical Data

Compressive Strength Development @ 6.75:1 fill ratio			
Hours	10°C, N/mm ²	24°C, N/mm ²	32°C, N/mm ²
8	-	-	-
16	-	66	69
24	-	76	90
48	31	90	110
72	45	93	110
96	55	96	110
Consistency (fill ratio)		6.75:1	5.06:1
Flexural Strength (BS 6319: Pt 3) cured @ 20°C ± 2°C for 7 days, 20°C N/mm ²		60	50
Creep (ASTM C1181-91 4.4 N/mm ² 60°C)		4.0 x 10 ⁻³	6.0 x 10 ⁻³
Tensile Strength (BS 6319: Pt 7) cured at 20°C ± 2°C for 7 days, 20°C N/mm ²		11.0	10.5
Co-efficient of Thermal Expansion (ASTM C531081) 23°C - 99°C, cm/cm/°C		34.0 x 10 ⁻⁶	41.0 x 10 ⁻⁶
Shrinkage, Unrestrained - Linear, %, (ASTM C531-85)		0.0005	0.00065
Density (ASTM C905-79), k/m ³		2150	1860
Volume per Unit - litres		53	48
Bond Strength to Steel - Tension, N/mm ² @ 20°C		21	
Bond Strength to Steel - Shear ,N/mm ² @ 20°C		28	
Colour		Dark Grey	
Flashpoints (Pensky-Martens Closed Cup), °C			
MASTERFLOW [®] 648 CP Plus Grout Liquid		204	
MASTERFLOW [®] 648 CP Plus Hardener		116	

Note

The data shown is based on controlled laboratory tests. Reasonable variations from the results shown can be expected. Field and laboratory tests should be controlled on the basis of the desired placing consistency.

Chemical resistance

MASTERFLOW[®] 648 CP PLUS resists non-oxidising mineral acids and salts, caustics, dilute oxidising acids and salts, and some organic acids and solvents. For more information, refer to BASF Construction Chemicals (UK) Ltd Technical Services Department.

Fill ratio

The fill ratio is the weight of the aggregate to combined resin and hardener components. MASTERFLOW[®] 648 CP PLUS is designed to be utilised at a variable fill ratio from the standard 6.75: 1 ratio to as low as 5.06:1 (hi-flow version)

The standard 53 litre unit of MASTERFLOW[®] 648 CP PLUS includes 100 kg (4 - 25 kg bags) of aggregate. This can be reduced to as low as 3 bag yielding 48 litres.

Resin and filler components can be purchased separately.

Unlike most epoxy grouts, MASTERFLOW[®] 648 CP PLUS maintains high bearing area when fill ratios are decreased. In addition, physical properties including high temperature performance are maintained.

By determining the proper fill ratio for a particular project and purchasing accordingly, the cost per litre, flow and physical properties are optimised.

A guideline for suggested fill ratios is shown below. In using this guide the temperature of the foundation and plate is the critical concern, however, grout and ambient temperature are also important.

Fill ratio guideline

Temperature	Very Thin Pours or Very Long Distance	Standard Pours
>32°C	4 bags	4 bags
21°C - 32°C	3½ -4 bags	4 bags
10°C - 21°C	3-3½ bags	3½ bags

Application Procedure

Refer to Installation Procedures Bulletin for detailed instructions.

Concrete preparation and sealing

The substrate onto which the grout is to be applied should be mechanically prepared to remove laitance and expose aggregate. The substrate must be sound and free of oil, dust, dirt, paint, curing compounds and other contaminants. Particular attention should be paid to bolt holes to ensure that these are water-free. Use vacuum and/or oil free compressed air to remove free standing water. The concrete surface must be clean and dry when the grout is poured. The concrete areas to be grouted should not be primed or sealed.

Preparation and priming of metal surfaces

Base plates, rails and other metal surfaces to be grouted should be cleaned to SA 2½ to obtain proper adhesion. Priming the metal surfaces is only required when a long delay between cleaning and grouting will allow corrosion and contamination.

Base plates, bolts, etc. must be clean and free of oil, grease, paint and other contaminants. Set and align equipment. If shims are to be removed after the grout has set, then lightly grease them for easy removal.

Formwork

Ensure formwork is secure and leakproof to prevent movement and grout loss during the placing and curing of the grout. The area should be free of excessive vibration. Shut down adjacent machinery until the grout has hardened. Formwork should be designed to allow a hydrostatic head of 150mm to be maintained throughout. On the side where the grout is to be poured, allow 150mm clearance between the sides of the form and the base plate of the machine.

On the opposite side allow at least 50-100mm for the head of the grout and 50mm clearance between the formwork and the edge of the base plate.

Mixing

Add all the contents of the hardener container to the resin component and mix thoroughly for at least 3 minutes. Transfer to a mechanical mixer. Add the aggregate, mixing thoroughly until a uniform consistency is obtained.

At low temperatures (between 5°C and 10°C) the flow characteristics of MASTERFLOW® 648 CP PLUS will be reduced and installation times increased.

Application Underplate:

Ensure sufficient material is available to complete the work and obtain a continuous fill.

Fill all the bolt pockets with grout before pouring the rest of the underplate grout. Pour the grout continuously from one side only to avoid air entrapment. Maintain a constant hydrostatic head of approximately 150mm, to promote flow. DO NOT vibrate. Lengths of metal or plastic strapping laid in the formwork prior to placing can be used to aid complete filling.

Placing techniques:

Diagram (A) illustrates typical placement of MASTERFLOW® 648 CP PLUS in the flowable state utilising straight pouring or pumping techniques to place a bedding mortar under bearing plates.

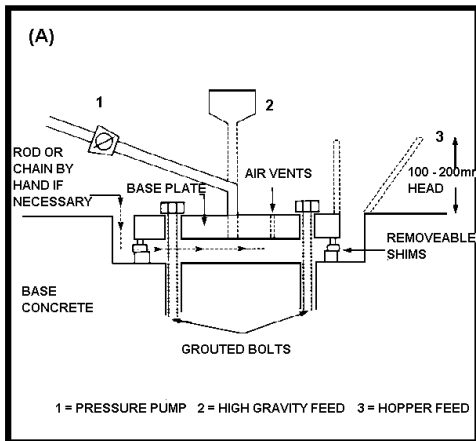

Finishing and clean up

A smooth finish may be obtained by spraying or brushing the surface before it hardens with MASTERKURE/FEB CLEANING NO.1 SOLVENT, or other suitable solvents, approximately 1 hour after the grout is poured. Best results can be obtained by smoothing the surface several times just prior to the hardening of the grout surface.

Tools and mixer must be cleaned immediately after use with MASTERKURE/FEB CLEANING NO.1 SOLVENT or other suitable solvents. Cured material can only be removed mechanically.

Pour thickness

MASTERFLOW® 648 CP PLUS can be used for deep pours. When pour thickness exceeds 150 mm use of steel reinforcement is recommended.

Curing

Cure time of the grout will depend upon the temperature of the base and foundation rather than the ambient air temperature. Unless the ambient air temperature has been constant for several days the foundation temperature will generally be lower than air temperature. A surface thermometer and field judgement should be used to determine actual cure rates. Cured grout should have a solid, almost metallic ring when struck close to the base with a hammer.

Working time

The following chart is a guide for the working time of a MASTERFLOW® 648 CP PLUS grout at various ambient temperatures. The working time of MASTERFLOW® 648 CP PLUS grout begins when the hardener is added to the liquid.

Temperature	Pot life
at 32°C	50 - 60 min
at 21°C	90 - 120 min
at 10°C	120 - 150 min

Packaging and yield

MASTERFLOW® 648 CP PLUS is available in unitised package sizes for your convenience.

MASTERFLOW® 648 CP PLUS

- 114.8 kg full unit yield 53 litres
- Liquid 10.8 kg - 1 pail
- Hardener 4.0 kg - 1 bottle
- Aggregate 25 kg - 4 bags
- Or
- 28.7 kg small unit yield 13 litres
- Liquid 2.7 kg - 1 pail
- Hardener 1.0 kg - 1 pail
- Aggregate 25 kg - 1 bag

When estimating due allowance for wastage must be made.



The Chemical Company

Storage

Store in cool dry conditions away from direct sunlight and at ambient temperatures.

Shelf Life

Up to 2 years when stored in unopened containers depending upon storage conditions.

Refer also to best before date.

BASF Construction Chemicals (UK) Ltd

PO Box 4

Earl Road

Cheadle Hulme

Cheadle

Cheshire

SK8 6QG

Tel: +44 (0) 161 485 6222

Fax +44 (0) 161 488 5220

www.basf-cc.co.uk

MASTERFLOW[®] 648 CP PLUS BASF Construction Chemicals (UK) Ltd Version 9 – July 2007

Health and Safety

*For full information on Health and Safety matters regarding this product the relevant Health and Safety Data Sheet should be consulted.

The following general comments apply to all products.

As with all chemical products, care should be taken during use and storage to avoid contact with eyes, mouth, skin and foodstuffs, (which may also be tainted with vapour until the product is fully cured and dried). Treat splashes to eyes and skin immediately. If accidentally ingested, seek medical attention. Keep away from children and animals. Reseal containers after use.

Solvent Based Products

Use in well ventilated areas; avoid inhaling. Suitable respiratory equipment may be needed, eg when spraying. Can cause skin, eye irritation. Wear protective eye shields and gloves during use. Do not smoke or allow sparks or naked lights when stored or in use.

Powder Products

Should be handled to minimise dust formation; use light mask if excessive dust unavoidable. Cement powders when wet or moistened can cause burns to skin and eyes which should be protected during use.

Resin Products

Can cause irritation, dermatitis or allergic reaction. Use protective equipment particularly for skin and eyes. Use only in well ventilated areas.

Spillage

Chemical products can cause damage; clean spillage immediately.

Disclaimer:

This information and all further technical advice is based on our present knowledge and experience. However, it implies no liability or other legal responsibility on our part, including with regard to existing third party intellectual property rights, especially patent rights. In particular, no warranty, whether express or implied, or guarantee of product properties in the legal sense is intended or implied. We reserve the right to make any changes according to technological progress or further developments. The customer is not released from the obligation to conduct careful inspection and testing of incoming goods. Performance of the product described herein should be verified by testing, which should be carried out only by qualified experts in the sole responsibility of a customer. Reference to trade names used by other companies is neither a recommendation, nor does it imply that similar products could not be used.